

SAW 868.3 MHz Filter

Bandwidth 0.45 MHz

AEC Part Number A190-868.3M1

Complies with Directive 2002/95/EC (RoHS)

PRELIMINARY DATA

Typical performance

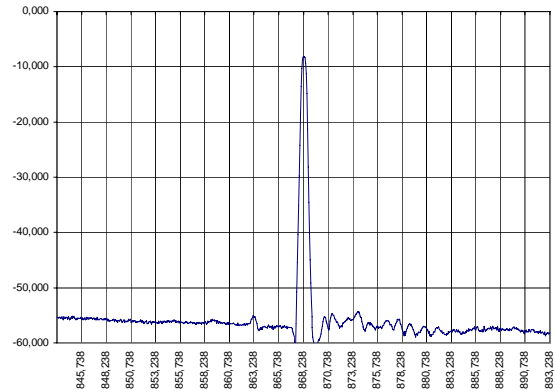
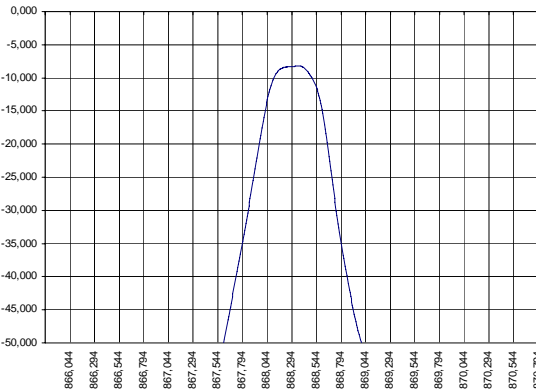

Specifications

Parameter	Unit	Min	Typ	Max
Central frequency	MHz	868.18	868.3	868.42
Inserted loss (matched)	dB	7.7	8	8.5
Bandwidth @-3dB	MHz	0.4	0.45	0.5
Bandwidth @-40dB	MHz	1.1	1.12	1.15
Bandwidth @-45dB	MHz	1.23	1.25	1.3
Amplitude ripple	dB	0.3	0.5	1
Ultimate rejection	dB	-	70	-
Substrate		-	36q	-
Temperature range	°C	-55		85

Notes:

1. The design, manufacturing process, and specifications of this filter are subject to change.
2. Specification valid for measurements in AEC test fixture

Case

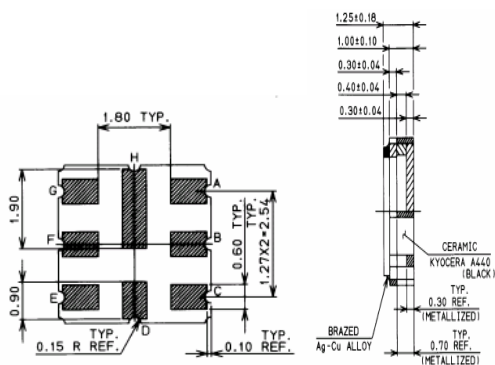

Matching

